

PRACTICE TEST

Mathematics

Grade 6

Student Name

School Name

District Name



RIDE Rhode Island
Department
of Education

Grade 6 Mathematics

PRACTICE TEST

SESSION 1

This session contains 20 questions.

*You may use your reference sheet during this session.
You may **not** use a calculator during this session.*



Directions

Read each question carefully and then answer it as well as you can. You must record all answers in this Practice Test Booklet.

For some questions, you will mark your answers by filling in the circles in your Practice Test Booklet. Make sure you darken the circles completely. Do not make any marks outside of the circles. If you need to change an answer, be sure to erase your first answer completely.

For other questions, you will need to fill in an answer grid. Directions for completing questions with answer grids are provided on the next page.

If a question asks you to show or explain your work, you must do so to receive full credit. Write your response in the space provided. Only responses written within the provided space will be scored.

Directions for Completing Questions with Answer Grids

1. Work the question and find an answer.
2. Enter your answer in the answer boxes at the top of the answer grid.
3. Print only one number or symbol in each box. Do not leave a blank box in the middle of an answer.
4. Under each answer box, fill in the circle that matches the number or symbol you wrote above. Make a solid mark that completely fills the circle.
5. Do not fill in a circle under an unused answer box.
6. Fractions cannot be entered into an answer grid and will not be scored. Enter fractions as decimals.
7. If you need to change an answer, be sure to erase your first answer completely.
8. See below for examples of how to correctly complete an answer grid.

Examples

-	1	4					
⊖							
⊙	⊙	⊙	⊙	⊙	⊙	⊙	⊙
0	0	0	0	0	0	0	0
1	●	1	1	1	1	1	1
2	2	2	2	2	2	2	2
3	3	3	3	3	3	3	3
4	4	●	4	4	4	4	4
5	5	5	5	5	5	5	5
6	6	6	6	6	6	6	6
7	7	7	7	7	7	7	7
8	8	8	8	8	8	8	8
9	9	9	9	9	9	9	9

	4	8	3	1	6		
⊖							
⊙	⊙	⊙	⊙	⊙	⊙	⊙	⊙
0	0	0	0	0	0	0	0
1	1	1	1	●	1	1	1
2	2	2	2	2	2	2	2
3	3	3	●	3	3	3	3
4	●	4	4	4	4	4	4
5	5	5	5	5	5	5	5
6	6	6	6	6	●	6	6
7	7	7	7	7	7	7	7
8	8	●	8	8	8	8	8
9	9	9	9	9	9	9	9

			6	5	.	3	
⊖							
⊙	⊙	⊙	⊙	⊙	⊙	●	⊙
0	0	0	0	0	0	0	0
1	1	1	1	1	1	1	1
2	2	2	2	2	2	2	2
3	3	3	3	3	3	●	3
4	4	4	4	4	4	4	4
5	5	5	5	●	5	5	5
6	6	6	●	6	6	6	6
7	7	7	7	7	7	7	7
8	8	8	8	8	8	8	8
9	9	9	9	9	9	9	9

	9	.	5	5	5	5	
⊖							
⊙	⊙	●	⊙	⊙	⊙	⊙	⊙
0	0	0	0	0	0	0	0
1	1	1	1	1	1	1	1
2	2	2	2	2	2	2	2
3	3	3	3	3	3	3	3
4	4	4	4	4	4	4	4
5	5	5	●	●	●	●	5
6	6	6	6	6	6	6	6
7	7	7	7	7	7	7	7
8	8	8	8	8	8	8	8
9	●	9	9	9	9	9	9

- 1 A mail carrier delivered mail to 84 houses in 3 hours. At what rate did the mail carrier deliver the mail?
- (A) 24 houses per hour
 - (B) 28 houses per hour
 - (C) 81 houses per hour
 - (D) 87 houses per hour

- 2 The location of point T is shown on this coordinate plane.

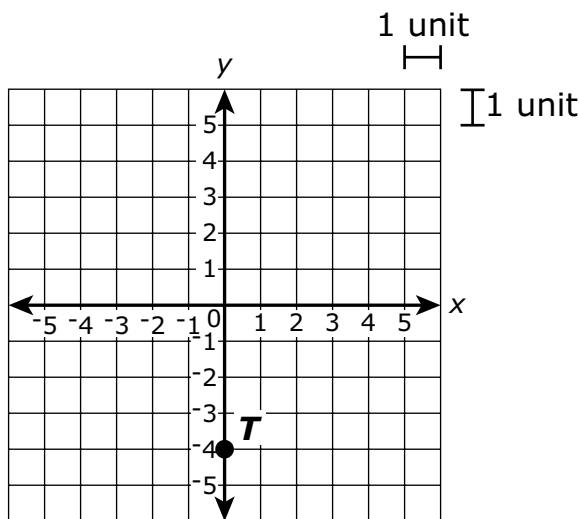

Point S is located 5 units to the right of point T .

Which of the following graphs shows the correct location of point S ?

Ⓐ

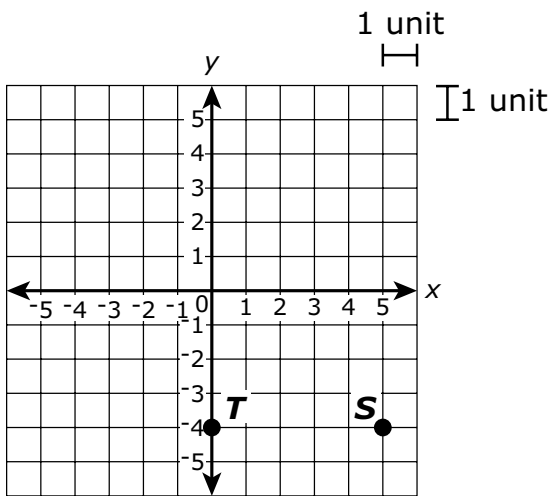

Ⓑ

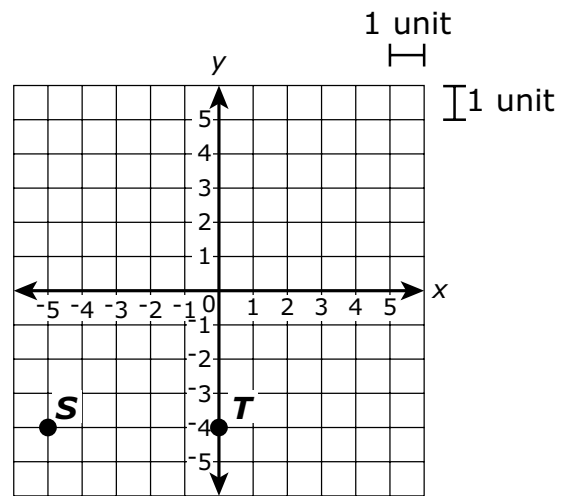

Ⓒ

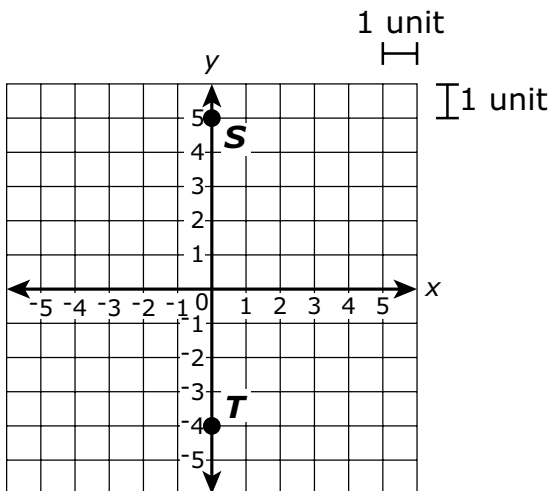

Ⓓ

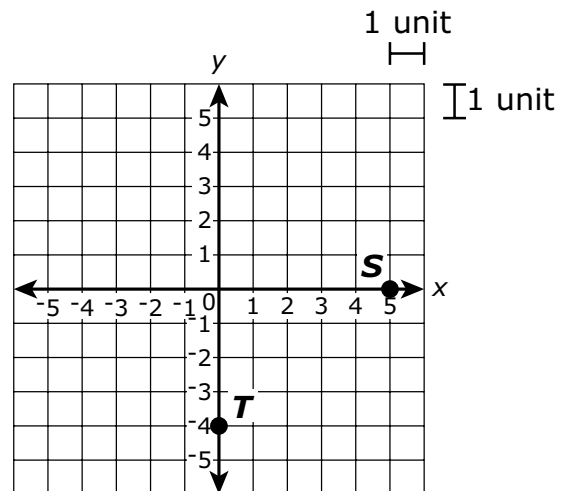

- 3 Diego writes 6 poems per week.

Which of the following expressions can be used to show the number of poems Diego writes in w weeks?

- (A) $6 \div w$
- (B) $6 \times w$
- (C) $6 + w$
- (D) $6 - w$

- 4 A group of middle school students went to an aquarium for a class trip. Afterward, the principal asked them several questions about their trip to the aquarium.

Which of the following questions that the principal asked are statistical questions?

Select the **two** statistical questions.

- (A) Did the aquarium have a gift shop?
- (B) Did the aquarium have an elevator?
- (C) Is the aquarium open on Tuesdays?
- (D) Would you like to visit this aquarium again?
- (E) What was your favorite exhibit at the aquarium?

- 5 A zookeeper counted the birds at a zoo. He recorded the following number of birds for each type of bird:
- 21 flamingos
 - 24 penguins
 - 6 storks

Which relationship between the different types of birds at the zoo can be represented by the ratio 7:8?

- Ⓐ flamingos to storks
- Ⓑ flamingos to penguins
- Ⓒ storks to all birds at the zoo
- Ⓓ penguins to all birds at the zoo

This question has four parts. Be sure to label each part of your response.

- 6 Molly, Ryan, and Bianca are cousins.
- Molly is m years old.
 - Ryan is 4 years older than Molly.
 - Bianca's age is y years less than twice Ryan's age.
- A. Write an expression that represents Ryan's age in terms of m .
- B. Molly is 5 years old. Use your expression from Part A to find Ryan's age, in years. Show or explain how you got your answer.
- C. Use your answer from Part B to write an expression that represents Bianca's age in terms of y .
- D. Use your expression from Part C to find Bianca's age, in years, if $y = 6$. Show or explain how you got your answer.

- 7 A carpenter has a block of wood in the shape of a rectangular prism, as shown. The block of wood has a mass of 4 kilograms.

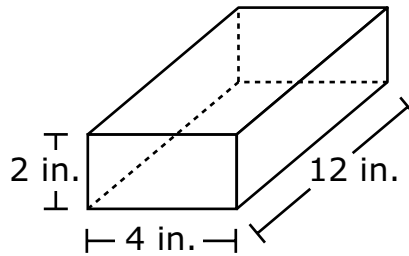

The carpenter cut the block of wood to make another shape. The new shape has a mass of 2 kilograms. Which of the following shapes could **not** be the shape the carpenter cut from the block of wood?

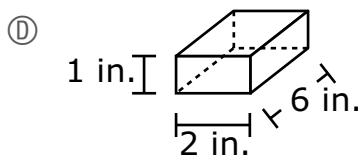
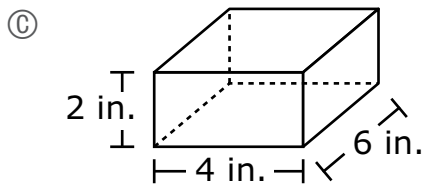
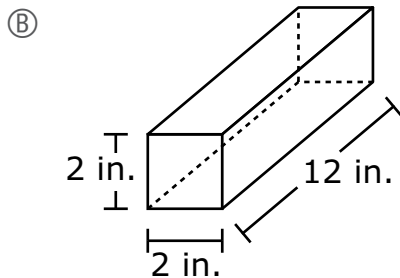
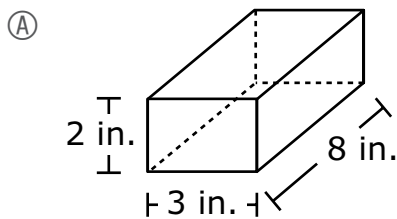

- 8 Members of a club are selling boxes of cookies. Each box of cookies costs the same amount. This table shows the total costs for different numbers of boxes of cookies.

Costs of Cookie Boxes

Number of Boxes of Cookies	Total Cost
1	\$3.50
2	\$7.00
3	\$10.50
4	\$14.00

Based on the data in the table, what would be the total cost, in dollars, of 10 boxes of cookies?

Enter your answer in the answer boxes at the top of the answer grid **and** completely fill the matching circles.

⊖							
⊙	⊙	⊙	⊙	⊙	⊙	⊙	⊙
0	0	0	0	0	0	0	0
1	1	1	1	1	1	1	1
2	2	2	2	2	2	2	2
3	3	3	3	3	3	3	3
4	4	4	4	4	4	4	4
5	5	5	5	5	5	5	5
6	6	6	6	6	6	6	6
7	7	7	7	7	7	7	7
8	8	8	8	8	8	8	8
9	9	9	9	9	9	9	9



- 9 A student wrote this word expression.

the quotient of four cubed and three to the fourth power

Which of the following is equivalent to the word expression?

- (A) $3^4 \times 4^3$
- (B) $3^4 \div 4^3$
- (C) $4^3 + 3^4$
- (D) $4^3 \div 3^4$

- 10 A student asks 10 classmates for the number of hours they each spent reading last week. The student creates this chart to show the responses.

Hours Spent Reading
7, 6, 5, 8, 5, 4, 7, 5, 6, 8

Which dot plot shows the number of hours the classmates spent reading last week?

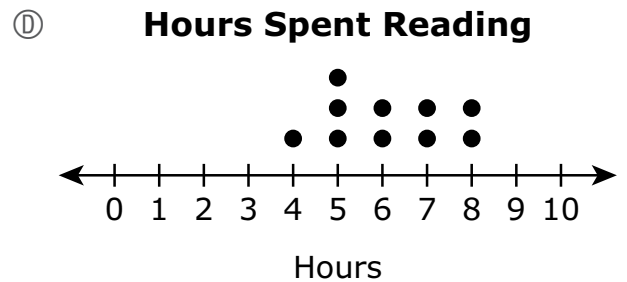
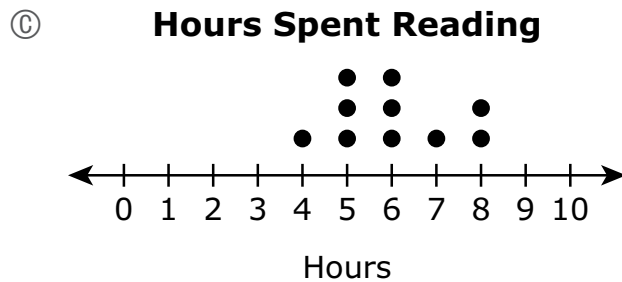
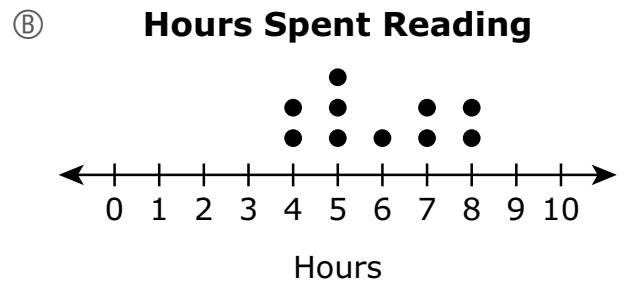
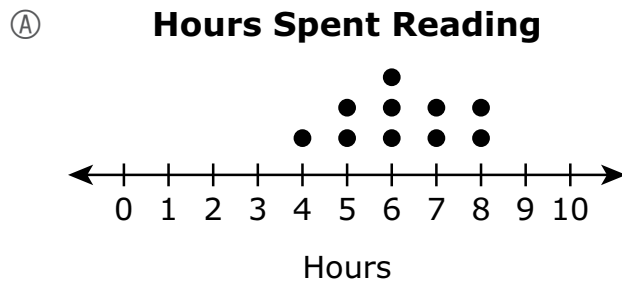

- 11 A net of a triangular prism and some of its dimensions are shown.

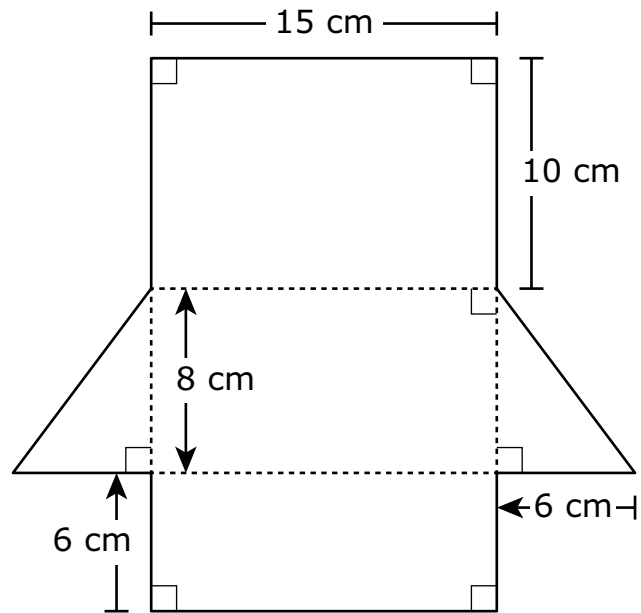

What is the total surface area, in square centimeters, of the triangular prism?

- (A) 198 square centimeters
- (B) 360 square centimeters
- (C) 408 square centimeters
- (D) 456 square centimeters

- 12 What is the value of y in this equation?

$$6y - 18 = 42$$

- (A) 0
- (B) 4
- (C) 10
- (D) 12
- 13 A farmer picked oranges and put them all into 9 boxes. Each box had the same number of oranges.

Which of the following could be the number of oranges the farmer picked?

- (A) 299
- (B) 281
- (C) 273
- (D) 261

This question has four parts. Be sure to label each part of your response.

- 14 There were 15 customers at a book sale. This dot plot shows the amount of money, in dollars, that each customer spent at the book sale.

Money Spent at Book Sale

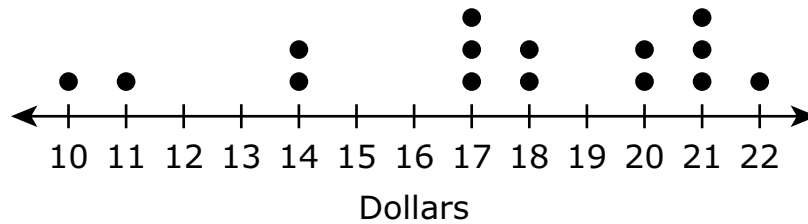

- A. Based on the dot plot, how many customers at the book sale spent exactly 17 dollars? Explain your reasoning.
- B. How many customers at the book sale spent **less** than the median amount of money spent at the book sale? Show or explain how you got your answer.
- C. How many customers at the book sale spent more than 14 dollars but less than 22 dollars? Show or explain how you got your answer.
- D. What **percent** of the customers at the book sale spent less than 20 dollars? Show or explain how you got your answer.

15 A teenager is saving money to buy a snowboard.

- The snowboard costs \$132, including sales tax.
- The teenager has already saved \$23.

Which of the following equations could be used to find m , the remaining amount of money, in dollars, the teenager must save to buy the snowboard?

Ⓐ $\frac{m}{23} = 132$

Ⓑ $23m = 132$

Ⓒ $m - 23 = 132$

Ⓓ $m + 23 = 132$

- 16 A quadrilateral has these vertices.

$$H(-3, 2), I(3, 2), J(5, -2), K(-5, -2)$$

Which of the following graphs shows quadrilateral $HIJK$?

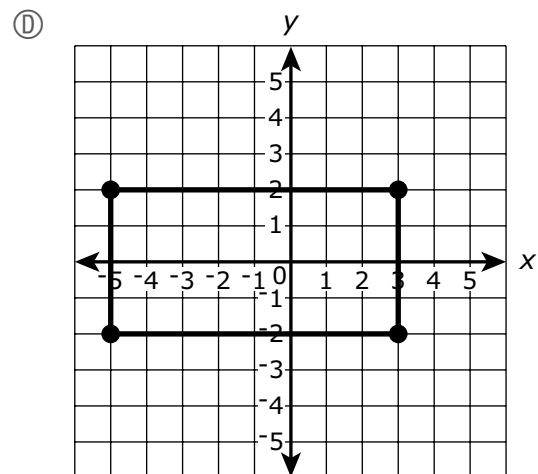
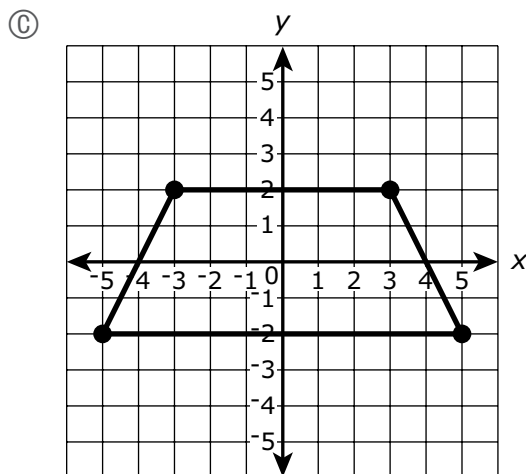
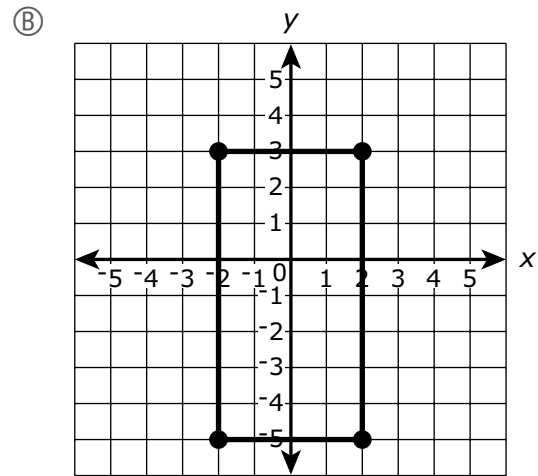
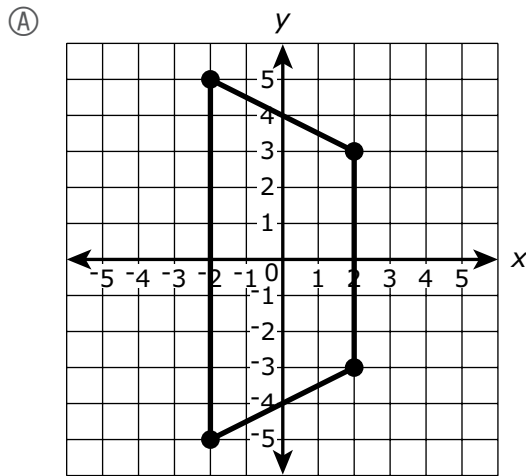

This question has two parts.

17 A cookie recipe requires the following ingredients:

- $\frac{1}{2}$ cup of butter
- 3 cups of flour
- 2 cups of sugar

A chef will make several batches of cookies using the recipe.

Part A

Which of the following statements about the ratios of the ingredients in the recipe is true?

- Ⓐ There are 4 cups of butter for every 1 cup of sugar.
- Ⓑ There are 4 cups of sugar for every 1 cup of butter.
- Ⓒ There are 4 cups of flour for every 1 cup of sugar.
- Ⓓ There are 4 cups of sugar for every 1 cup of flour.

Part B

Which of the following statements about the ratios of the ingredients in the recipe is true?

- Ⓐ There are $\frac{3}{2}$ cups of flour for every 1 cup of sugar.
- Ⓑ There are $\frac{3}{2}$ cups of sugar for every 1 cup of flour.
- Ⓒ There are $\frac{3}{2}$ cups of butter for every 1 cup of sugar.
- Ⓓ There are $\frac{3}{2}$ cups of sugar for every 1 cup of butter.

- 18** A barber recorded the number of customers whose hair he cut each day last week.

Which of the following measures **best** describes the spread of the barber's data?

- (A) mean
- (B) mode
- (C) range
- (D) median

- 19** At a carnival, only people taller than 48 inches are allowed to ride the roller coaster.

Which of the following inequalities best describes all the possible heights, h , in inches, of people who are allowed to ride the roller coaster?

- (A) $h > 49$
- (B) $h < 49$
- (C) $h > 48$
- (D) $h < 48$

- 20** Which of the following situations could **best** be represented by the number -3 ?

- (A) A server receives a 3 dollar tip.
- (B) A thermometer shows a temperature of 3°F .
- (C) A student earns 3 points of extra credit on a quiz.
- (D) A player loses 3 points in the first turn of a video game.

Grade 6 Mathematics

PRACTICE TEST

SESSION 2

This session contains 20 questions.

*You may use your reference sheet during this session.
You may **not** use a calculator during this session.*



Directions

Read each question carefully and then answer it as well as you can. You must record all answers in this Practice Test Booklet.

For some questions, you will mark your answers by filling in the circles in your Practice Test Booklet. Make sure you darken the circles completely. Do not make any marks outside of the circles. If you need to change an answer, be sure to erase your first answer completely.

For other questions, you will need to fill in an answer grid. Directions for completing questions with answer grids are provided on the next page.

If a question asks you to show or explain your work, you must do so to receive full credit. Write your response in the space provided. Only responses written within the provided space will be scored.

Directions for Completing Questions with Answer Grids

1. Work the question and find an answer.
2. Enter your answer in the answer boxes at the top of the answer grid.
3. Print only one number or symbol in each box. Do not leave a blank box in the middle of an answer.
4. Under each answer box, fill in the circle that matches the number or symbol you wrote above. Make a solid mark that completely fills the circle.
5. Do not fill in a circle under an unused answer box.
6. Fractions cannot be entered into an answer grid and will not be scored. Enter fractions as decimals.
7. If you need to change an answer, be sure to erase your first answer completely.
8. See below for examples of how to correctly complete an answer grid.

Examples

-	1	4				
⊖						
⊙	⊙	⊙	⊙	⊙	⊙	⊙
0	0	0	0	0	0	0
1	●	1	1	1	1	1
2	2	2	2	2	2	2
3	3	3	3	3	3	3
4	4	●	4	4	4	4
5	5	5	5	5	5	5
6	6	6	6	6	6	6
7	7	7	7	7	7	7
8	8	8	8	8	8	8
9	9	9	9	9	9	9

	4	8	3	1	6	
⊖						
⊙	⊙	⊙	⊙	⊙	⊙	⊙
0	0	0	0	0	0	0
1	1	1	1	●	1	1
2	2	2	2	2	2	2
3	3	3	●	3	3	3
4	●	4	4	4	4	4
5	5	5	5	5	5	5
6	6	6	6	6	●	6
7	7	7	7	7	7	7
8	8	●	8	8	8	8
9	9	9	9	9	9	9

			6	5	.	3
⊖						
⊙	⊙	⊙	⊙	⊙	⊙	⊙
0	0	0	0	0	0	0
1	1	1	1	1	1	1
2	2	2	2	2	2	2
3	3	3	3	3	3	●
4	4	4	4	4	4	4
5	5	5	5	●	5	5
6	6	6	●	6	6	6
7	7	7	7	7	7	7
8	8	8	8	8	8	8
9	9	9	9	9	9	9

	9	.	5	5	5	5
⊖						
⊙	⊙	⊙	⊙	⊙	⊙	⊙
0	0	0	0	0	0	0
1	1	1	1	1	1	1
2	2	2	2	2	2	2
3	3	3	3	3	3	3
4	4	4	4	4	4	4
5	5	5	●	●	●	●
6	6	6	6	6	6	6
7	7	7	7	7	7	7
8	8	8	8	8	8	8
9	●	9	9	9	9	9

- 21 Consider this inequality.

$$5c > 10$$

Which of the following is a solution to the inequality?

- Ⓐ 0
 - Ⓑ 1
 - Ⓒ 2
 - Ⓓ 3
- 22 Jared played a game ten times. He recorded the number of points he earned at the end of each game. This list shows the data he recorded.

2, 3, 4, 5, 7, 7, 9, 9, 9, 10

Based on the data, which of the following statements is true?

- Ⓐ The mode of the data is equal to 7 and the mean of the data is equal to 8.
- Ⓑ The median of the data is equal to 7 and the range of the data is equal to 8.
- Ⓒ The mean of the data is equal to 7 and the median of the data is equal to 8.
- Ⓓ The range of the data is equal to 7 and the mode of the data is equal to 8.

- 23 What is the value of this expression when $b = 4$?

$$15 - 3(b)$$

Enter your answer in the answer boxes at the top of the answer grid **and** completely fill the matching circles.

-							
•	•	•	•	•	•	•	•
0	0	0	0	0	0	0	0
1	1	1	1	1	1	1	1
2	2	2	2	2	2	2	2
3	3	3	3	3	3	3	3
4	4	4	4	4	4	4	4
5	5	5	5	5	5	5	5
6	6	6	6	6	6	6	6
7	7	7	7	7	7	7	7
8	8	8	8	8	8	8	8
9	9	9	9	9	9	9	9

- 24 Consider the numbers -24 and -18 .

Which of the following statements about the numbers are true?

Select the **two** correct answers.

- (A) The number -24 is less than the number -18 .
- (B) The number -24 is greater than the number -18 .
- (C) The expression $|-24|$ is equal to the expression $|-18|$.
- (D) The expression $|-24|$ is less than the expression $|-18|$.
- (E) The expression $|-24|$ is greater than the expression $|-18|$.

- 25 At a middle school, the sixth-grade students and seventh-grade students collected cans for recycling.
- Of the 2000 cans the sixth-grade students collected, 65% were soda cans.
 - Of the 1500 cans the seventh-grade students collected, 80% were soda cans.

Which of the following statements about the numbers of soda cans the students collected are true?

Select the **two** correct answers.

- Ⓐ The sixth-grade students collected 1200 soda cans.
- Ⓑ The sixth-grade students collected 1875 soda cans.
- Ⓒ The sixth-grade students collected 1300 soda cans.
- Ⓓ The seventh-grade students collected 1200 soda cans.
- Ⓔ The seventh-grade students collected 1875 soda cans.
- Ⓕ The seventh-grade students collected 1300 soda cans.

- 26 The length of a yellow ribbon is 6.75 inches. The length of a green ribbon is greater than the length of the yellow ribbon.

Which of the following number lines shows the graph of an inequality that represents all the possible lengths, in inches, of the green ribbon?

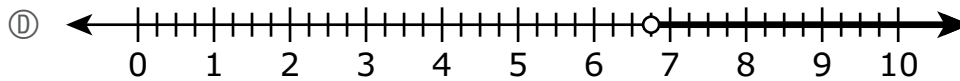
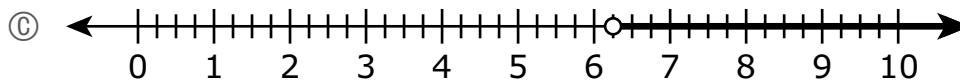
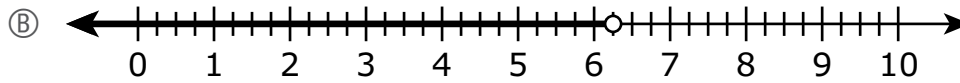
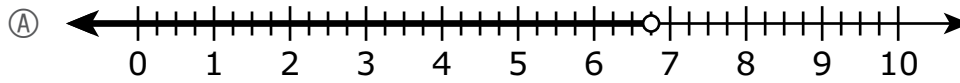

This question has four parts. Be sure to label each part of your response.

- 27 Figure $JKLM$ is composed of triangle JKN and trapezoid $KLMN$, and some of their measurements are shown.

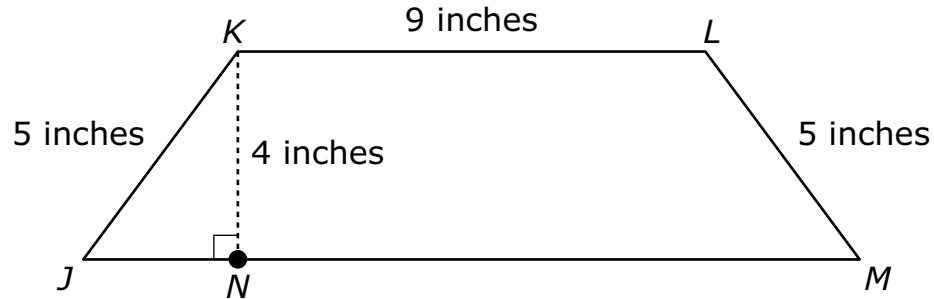

The base of figure $JKLM$ is 15 inches in length. Line segment JN is 3 inches in length.

- A. What is the length, in inches, of line segment NM ?
- B. What is the area, in square inches, of triangle JKN ? Show or explain how you got your answer.
- C. What is the area, in square inches, of trapezoid $KLMN$? Show or explain how you got your answer.
- D. What is the total area, in square inches, of figure $JKLM$? Show or explain how you got your answer.

28 Which of the following equations is true?

- (A) $0.34 + 5.2 = 8.6$
- (B) $0.56 \div 0.07 = 8$
- (C) $0.12 \times 0.3 = 0.36$
- (D) $0.97 - 0.05 = 0.47$

29 Consider this expression.

$$5m + 7$$

Which of the following is equivalent to the expression?

- (A) $12m$
- (B) $7 + 5m$
- (C) $7m + 5$
- (D) $5(m + 7)$

30 A farmer is planting carrot seeds and pepper seeds in his garden. For every 60 carrot seeds the farmer plants, he plants 12 pepper seeds.

Based on this information, which of the following statements is true?

- (A) The ratio of pepper seeds to carrot seeds is 60:12 because 60 pepper seeds are planted for every 12 carrot seeds.
- (B) The ratio of pepper seeds to carrot seeds is 60:12 because there are always 48 fewer carrot seeds planted than pepper seeds.
- (C) The ratio of pepper seeds to carrot seeds is 12:60 because 12 pepper seeds are planted for every 60 carrot seeds.
- (D) The ratio of pepper seeds to carrot seeds is 12:60 because there are always 48 fewer pepper seeds planted than carrot seeds.

- 31** A teacher wrote this expression on the board.

$$40a - 16b$$

Which of the following are equivalent to the expression the teacher wrote?

Select the **two** equivalent expressions.

- Ⓐ $4(10a - 16b)$
 - Ⓑ $4(10a - 4b)$
 - Ⓒ $8a(5 - 2)$
 - Ⓓ $8(5a - 2b)$
 - Ⓔ $24ab$
- 32** Which of the following numbers are on opposite sides of zero on the number line?
- Ⓐ 0 and 2
 - Ⓑ 4 and 3
 - Ⓒ 5 and -6
 - Ⓓ -7 and -8

- 33 A family drank 4 gallons of juice over 5 weeks. During this time period, at what rate did the family drink juice?
- Ⓐ $\frac{4}{5}$ gallon per week
 - Ⓑ $\frac{5}{4}$ gallons per week
 - Ⓒ 1 gallon per week
 - Ⓓ 9 gallons per week

- 34 This graph represents the number of copies a copy machine can make in different numbers of minutes.

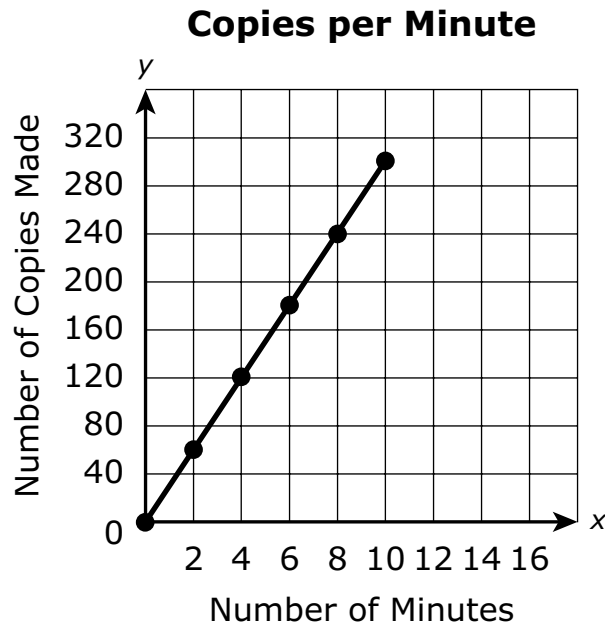

Based on the graph, which of the following is **closest** to the total number of copies the machine can make in 5 minutes?

- (A) 125
- (B) 150
- (C) 175
- (D) 200

This question has four parts. Be sure to label each part of your response.

35 A store received a shipment of the following items:

- 256 cans of soup
- 1,632 eggs

A. A store clerk will arrange the cans of soup in 4 rows. There will be an equal number of cans in each row.

How many cans of soup will the clerk arrange in each row? Show or explain how you got your answer.

B. What is another way the clerk could arrange the 256 cans of soup in rows and still have an equal number of cans in each row? Show or explain how you got your answer.

C. The 1,632 eggs the store received were shipped in cartons that each contain 12 eggs.

- The clerk will place all the eggs in an empty cooler.
- Each shelf of the cooler holds 17 cartons of eggs.

How many shelves are needed to hold all of the cartons of eggs? Show or explain how you got your answer.

D. The store sells 34 cartons of eggs each day.

How many days will it take until the store sells all the eggs it received? Show or explain how you got your answer.

- 36 A museum worker recorded the ages, in years, of the first 20 children who visited a new exhibit, as shown.

4	9	1	15	12
3	5	8	1	11
2	17	3	10	16
7	2	6	9	8

The museum worker will use her data to create a histogram to represent the ages of the first 20 children who visited the new exhibit.

Which of the following histograms represents the data?

(A) **Ages of Children at Exhibit**

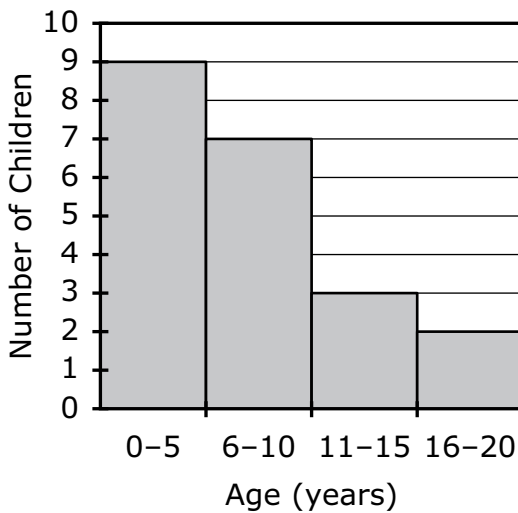

(B) **Ages of Children at Exhibit**

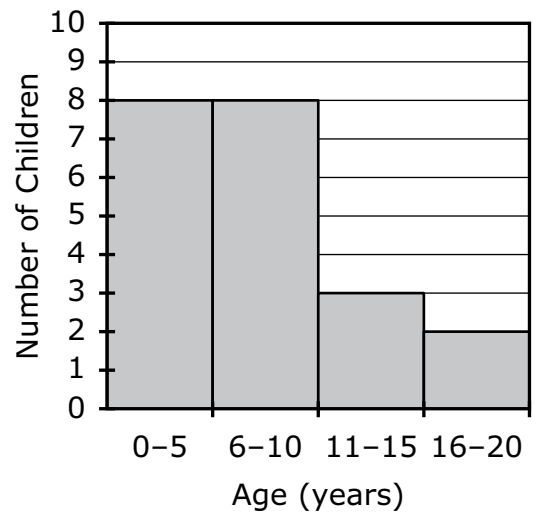

(C) **Ages of Children at Exhibit**

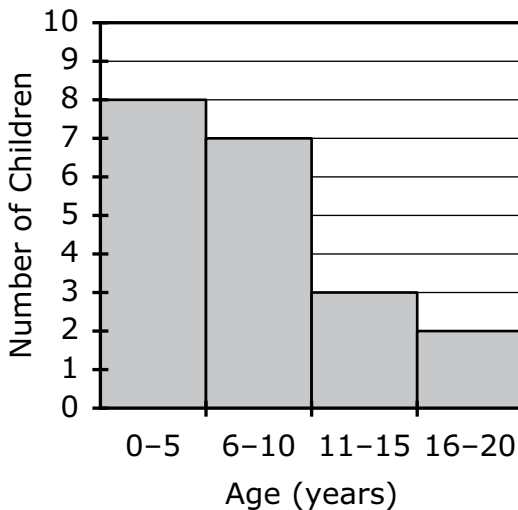

(D) **Ages of Children at Exhibit**

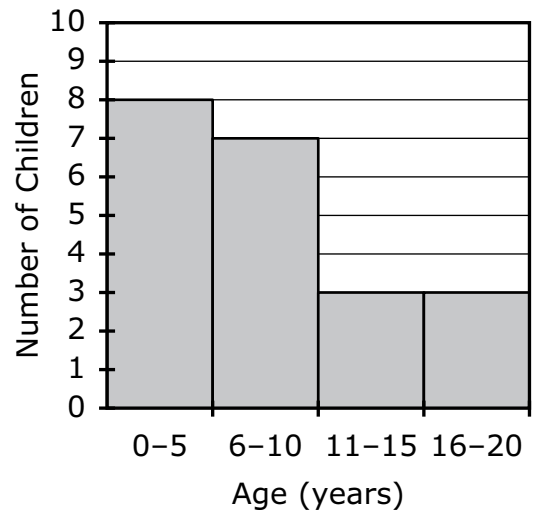

- 37 Robin reads 5 pages of a book in 4 minutes. Based on this rate, what is the total number of minutes it will take Robin to read 200 pages?
- Ⓐ 100 minutes
 - Ⓑ 160 minutes
 - Ⓒ 200 minutes
 - Ⓓ 250 minutes

This question has two parts.

- 38 A student used congruent cubes to build a right rectangular prism. The prism and its dimensions are shown in this diagram.

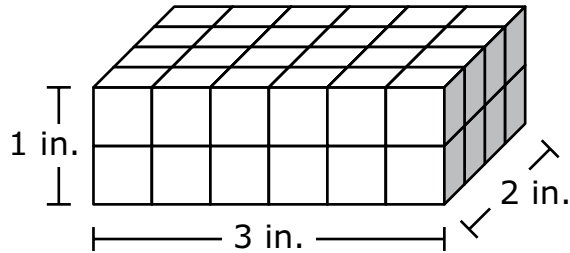

Part A

What is the volume, in cubic inches, of the prism?

- Ⓐ 6
- Ⓑ 12
- Ⓒ 36
- Ⓓ 48

Part B

What is the volume, in cubic inches, of 1 of the cubes?

- Ⓐ 1
- Ⓑ $\frac{1}{2}$
- Ⓒ $\frac{1}{4}$
- Ⓓ $\frac{1}{8}$

- 39** Victoria scored a total of 9 points in the first basketball game of the season. She scored 5 points per game in each of the other x basketball games she played that season.

Which of the following expressions represents the total number of points Victoria scored in the basketball games for the whole season?

- (A) $5x$
- (B) $14x$
- (C) $5 + 9x$
- (D) $9 + 5x$
- 40** The scale on a map shows that 1 inch represents 18 miles. The distance on the map between Olivia's town and her grandmother's town is 4.5 inches.

What is the actual distance between the two towns?

- (A) 4 miles
- (B) 22.5 miles
- (C) 72.5 miles
- (D) 81 miles