

PRACTICE TEST

Mathematics

Grade 5

---

Student Name

---

School Name

---

District Name



**RIDE** Rhode Island  
Department  
of Education

# Grade 5 Mathematics

## PRACTICE TEST

### SESSION 1

This session contains 20 questions.

*You may use your reference sheet during this session.  
You may **not** use a calculator during this session.*



### Directions

Read each question carefully and then answer it as well as you can. You must record all answers in this Practice Test Booklet.

For some questions, you will mark your answers by filling in the circles in your Practice Test Booklet. Make sure you darken the circles completely. Do not make any marks outside of the circles. If you need to change an answer, be sure to erase your first answer completely.

For other questions, you will need to fill in an answer grid. Directions for completing questions with answer grids are provided on the next page.

If a question asks you to show or explain your work, you must do so to receive full credit. Write your response in the space provided. Only responses written within the provided space will be scored.

**Directions for Completing Questions with Answer Grids**

1. Work the question and find an answer.
2. Enter your answer in the answer boxes at the top of the answer grid.
3. Print only one number or symbol in each box. Do not leave a blank box in the middle of an answer.
4. Under each answer box, fill in the circle that matches the number or symbol you wrote above. Make a solid mark that completely fills the circle.
5. Do not fill in a circle under an unused answer box.
6. If you need to change an answer, be sure to erase your first answer completely.
7. See below for examples of how to correctly complete an answer grid.

**Examples**

<b>0</b>	<b>.</b>	<b>4</b>	<b>3</b>	<b>2</b>	
<input type="radio"/>	<input checked="" type="radio"/>	<input type="radio"/>	<input type="radio"/>	<input type="radio"/>	<input type="radio"/>
<input checked="" type="radio"/>	0	0	0	0	0
1	1	1	1	1	1
2	2	2	2	<input checked="" type="radio"/>	2
3	3	3	<input checked="" type="radio"/>	3	3
4	4	<input checked="" type="radio"/>	4	4	4
5	5	5	5	5	5
6	6	6	6	6	6
7	7	7	7	7	7
8	8	8	8	8	8
9	9	9	9	9	9

		<b>.</b>	<b>2</b>	<b>5</b>	
<input type="radio"/>	<input type="radio"/>	<input checked="" type="radio"/>	<input type="radio"/>	<input type="radio"/>	<input type="radio"/>
0	0	0	0	0	0
1	1	1	1	1	1
2	2	2	<input checked="" type="radio"/>	2	2
3	3	3	3	3	3
4	4	4	4	4	4
5	5	5	5	<input checked="" type="radio"/>	5
6	6	6	6	6	6
7	7	7	7	7	7
8	8	8	8	8	8
9	9	9	9	9	9

			<b>4</b>	<b>3</b>	<b>8</b>
<input type="radio"/>	<input type="radio"/>	<input type="radio"/>	<input type="radio"/>	<input type="radio"/>	<input type="radio"/>
0	0	0	0	0	0
1	1	1	1	1	1
2	2	2	2	2	2
3	3	3	3	<input checked="" type="radio"/>	3
4	4	4	<input checked="" type="radio"/>	4	4
5	5	5	5	5	5
6	6	6	6	6	6
7	7	7	7	7	7
8	8	8	8	8	<input checked="" type="radio"/>
9	9	9	9	9	9

<b>6</b>	<b>8</b>	<b>1</b>	<b>9</b>		
<input type="radio"/>	<input type="radio"/>	<input type="radio"/>	<input type="radio"/>	<input type="radio"/>	<input type="radio"/>
0	0	0	0	0	0
1	1	<input checked="" type="radio"/>	1	1	1
2	2	2	2	2	2
3	3	3	3	3	3
4	4	4	4	4	4
5	5	5	5	5	5
<input checked="" type="radio"/>	6	6	6	6	6
7	7	7	7	7	7
8	<input checked="" type="radio"/>	8	8	8	8
9	9	9	<input checked="" type="radio"/>	9	9

- 1** Olga ordered 144 packages of beads from a craft store. Each package contains 25 beads.

What is the total number of beads Olga ordered?

- Ⓐ 1008
- Ⓑ 2500
- Ⓒ 3380
- Ⓓ 3600

- 2 A child ate  $\frac{1}{2}$  of an apple pie, and her sister ate  $\frac{1}{3}$  of the same pie.

In which of the following fraction models does the shaded part show the **total** fraction of the pie eaten by the two sisters?

(A)

**Pie**

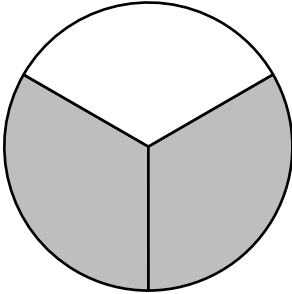

(B)

**Pie**

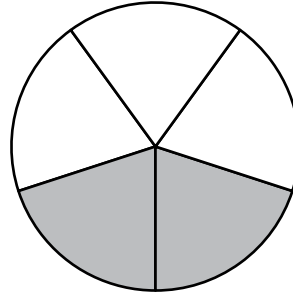

(C)

**Pie**

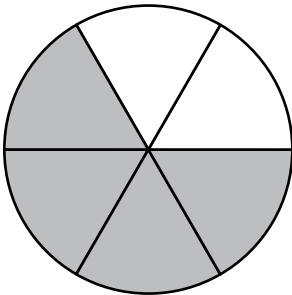

(D)

**Pie**

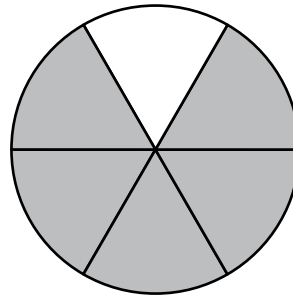

- 3 The location of Point  $B$  on a coordinate plane is represented by the ordered pair  $(8, 4)$ .

Which of the following statements describes the location of Point  $B$  on the coordinate plane?

- Ⓐ Point  $B$  is 4 units to the right of the origin and 8 units up from the origin.
- Ⓑ Point  $B$  is 8 units to the right of the origin and 4 units up from the origin.
- Ⓒ Point  $B$  is 4 units to the left of the origin and 8 units down from the origin.
- Ⓓ Point  $B$  is 8 units to the left of the origin and 4 units down from the origin.

- 4 Which of the following expressions is equivalent to  $5 \times \frac{1}{2}$ ?

- Ⓐ  $5 \times 1 \div 2$
- Ⓑ  $5 \times 2 \div 1$
- Ⓒ  $(5 \times 1) \div (5 \times 2)$
- Ⓓ  $(5 \times 2) \div (5 \times 1)$

- 5 A student wants to round this number.

89.473

Which of these statements about rounding the number are correct?

Select the **three** correct answers.

- Ⓐ The number 89.473 rounded to the nearest one is 89.
- Ⓑ The number 89.473 rounded to the nearest one is 90.
- Ⓒ The number 89.473 rounded to the nearest tenth is 89.47.
- Ⓓ The number 89.473 rounded to the nearest tenth is 89.5.
- Ⓔ The number 89.473 rounded to the nearest hundredth is 89.46.
- Ⓕ The number 89.473 rounded to the nearest hundredth is 89.47.

**This question has four parts. Be sure to label each part of your response.**

**6** A city planner is using the coordinate plane shown in your answer space to design a new playground. She has already plotted the location of the swings.

A. She will locate the slide at the point  $(13, 5)$ .

On the coordinate plane provided in your answer space, plot the point that represents the location of the slide.

B. What is the ordered pair that represents the location of the swings on the coordinate plane provided in your answer space?

C. The planner will locate the restroom 9 units from the origin along the  $x$ -axis and 2 units from the origin along the  $y$ -axis.

What is an ordered pair that she can use to represent the location of the restroom?

D. The planner will locate a picnic area 3 units away from the swings on the coordinate plane.

What are **two** ordered pairs that she can use to represent possible locations of the picnic area? Show or explain how you found your answers.

**Write your answers on the next page.**



- 7 Which of the following values belong in the  $\square$  to make this statement true?

$$11 \times \frac{\square}{5} \text{ is greater than } 11.$$

Select the **three** correct answers.

- Ⓐ 3
- Ⓑ 7
- Ⓒ 8
- Ⓓ 4
- Ⓔ 6
- Ⓕ 5

- 8 The prices for renting a bicycle from Leo's Bike Shop are shown in this box.

<b>Bicycle Rental Prices</b>
\$6.50 for the first hour
\$1.50 for each additional hour

What is the total price for renting a bicycle from Leo's Bike Shop for 3 hours?

- Ⓐ \$8.00
- Ⓑ \$9.50
- Ⓒ \$12.50
- Ⓓ \$13.00

- 9 This list shows the shoe sizes of eight students in a fifth-grade class.

**Student's Shoe Sizes**

Name	Shoe Size
Becca	7
Cara	$6\frac{1}{2}$
Dean	$6\frac{1}{2}$
Kareem	$7\frac{1}{2}$
Leah	6
Luke	8
Suzanne	$6\frac{1}{2}$
Wally	$7\frac{1}{2}$

Which of the following line plots correctly represents the shoe sizes of the eight students in the fifth-grade class?

Ⓐ Student's Shoe Sizes

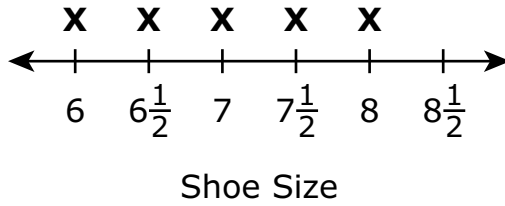

Ⓑ Student's Shoe Sizes

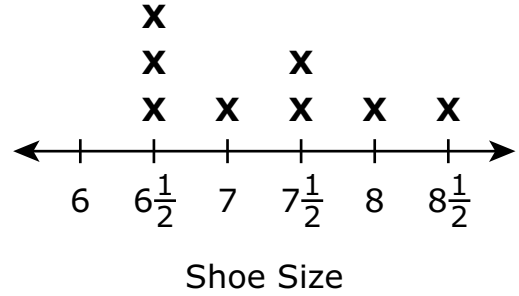

Ⓒ Student's Shoe Sizes

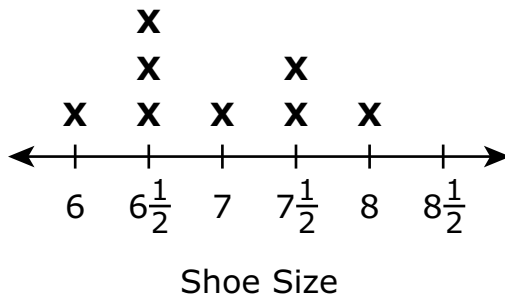

Ⓓ Student's Shoe Sizes

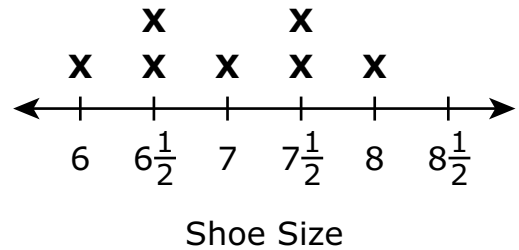

- 10 Tim wrote this expression.

$$4 \times (5 + 2)$$

Which of the following is equivalent to his expression?

- Ⓐ 11
  - Ⓑ 22
  - Ⓒ 28
  - Ⓓ 40
- 11 In which of the following numbers does the 9 have a value that is  $\frac{1}{10}$  the value of the 9 in the number 871.953?

Select the **two** correct answers.

- Ⓐ 146.792
- Ⓑ 219.73
- Ⓒ 394.821
- Ⓓ 429.13
- Ⓔ 593.427
- Ⓕ 652.49

- 12 A teacher wrote this expression to solve a math problem.

$$4 \div \frac{1}{12}$$

Which of the following could be the problem the teacher is solving?

- (A) An athlete will run 4 miles and then walk  $\frac{1}{12}$  mile more. What is the total number of miles the athlete will run and walk?
- (B) A group of friends will share 4 whole pies. Each friend will receive  $\frac{1}{12}$  of a whole pie. What is the total number of friends that will receive a piece of pie?
- (C) A person will work a total of 4 hours this weekend. The person will work  $\frac{1}{12}$  hour on Saturday. What is the total number of hours the person will work on Sunday?
- (D) A cook will use eggs in 4 recipes this week. The cook will use  $\frac{1}{12}$  of a carton of eggs in each recipe. What is the total number of cartons of eggs the cook will use this week?

- 13 Write this number in standard form.

sixty-three and five hundred forty-six thousandths

Enter your answer in the answer boxes at the top of the answer grid **and** completely fill the matching circles.

⊙	⊙	⊙	⊙	⊙	⊙	⊙
0	0	0	0	0	0	0
1	1	1	1	1	1	1
2	2	2	2	2	2	2
3	3	3	3	3	3	3
4	4	4	4	4	4	4
5	5	5	5	5	5	5
6	6	6	6	6	6	6
7	7	7	7	7	7	7
8	8	8	8	8	8	8
9	9	9	9	9	9	9



This question has four parts. Be sure to label each part of your response.

- 14 A toy company produces wooden blocks. Each block is in the shape of a cube with an edge length of 2 inches (in.), as shown in this diagram.

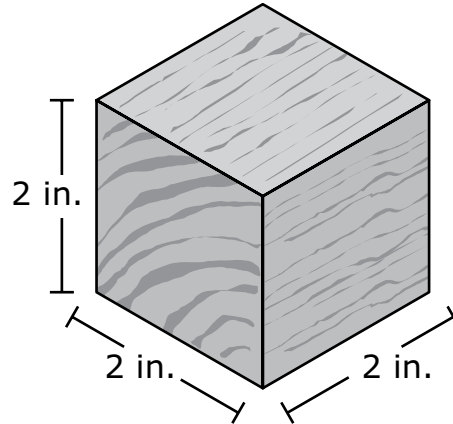

- A. What is the volume, in cubic inches, of each block? Show or explain how you got your answer.
- B. The toy company packs the blocks in cartons. Each carton is in the shape of a right rectangular prism and is completely filled, with no gaps or overlaps.
- The carton has a base area of 240 square inches.
  - The carton has a height of 12 inches.

What is the volume, in cubic inches, of the carton? Show or explain how you got your answer.

- C. What is the greatest number of blocks that can fit in one carton, with no gaps or overlaps? Show or explain how you got your answer.
- D. The toy company plans to start making a larger carton that holds exactly 1,000 blocks, with no gaps or overlaps.

What could be the measurements, in inches, of the larger carton's length, width, **and** height? Show or explain how you got your answers.

**Write your answers on the next page.**



- 15** The 7 children in a family equally shared 4 pizzas. All the pizzas were the same size. Which fraction represents the amount of pizza in each child's share?
- Ⓐ  $\frac{4}{7}$
- Ⓑ  $\frac{7}{4}$
- Ⓒ  $1\frac{3}{7}$
- Ⓓ  $1\frac{4}{7}$
- 16** A food company packages flavor cubes used for making soup. The flavor cubes are packaged in a box that is in the shape of a rectangular prism.
- Each flavor cube has an edge length of 1 centimeter.
  - Each box holds exactly 2 layers of flavor cubes with no gaps or overlaps.
  - Each layer in the box holds 9 flavor cubes.

What is the volume of one box of flavor cubes?

- Ⓐ 12 cubic centimeters
- Ⓑ 13 cubic centimeters
- Ⓒ 18 cubic centimeters
- Ⓓ 19 cubic centimeters

This question has two parts.

**17** Part A

Which of these expressions have a product greater than  $\frac{2}{3}$ ?

Select the **three** correct answers.

(A)  $\frac{2}{3} \times \frac{7}{8}$

(B)  $\frac{2}{3} \times \frac{3}{2}$

(C)  $\frac{2}{3} \times \frac{3}{5}$

(D)  $\frac{2}{3} \times \frac{3}{3}$

(E)  $\frac{2}{3} \times 3$

(F)  $\frac{2}{3} \times 1\frac{1}{8}$

**Part B**

Which of the following fractions can be multiplied by 5 to get a product that is **less than** 5?

(A)  $\frac{1}{3}$

(B)  $\frac{3}{2}$

(C)  $\frac{5}{1}$

(D)  $\frac{1}{1}$

- 18 A baker can decorate one cake in  $\frac{2}{3}$  hour.

What is the total number of hours the baker needs to decorate  $4\frac{1}{2}$  cakes?

- Ⓐ 3 hours
- Ⓑ  $4\frac{2}{6}$  hours
- Ⓒ  $5\frac{1}{6}$  hours
- Ⓓ 6 hours

- 19 Charlotte added 550 milliliters of orange juice to 500 milliliters of pineapple juice to make fruit punch.

What is the total amount of fruit punch, in **liters**, that Charlotte made?

- Ⓐ 1.0
- Ⓑ 1.5
- Ⓒ 1.05
- Ⓓ 1.005

- 20 A factory worker packed 1,576 cans of corn into boxes. The worker put 8 cans of corn into each box.

What is the total number of boxes the worker packed?

- Ⓐ 160
- Ⓑ 176
- Ⓒ 192
- Ⓓ 197

# Grade 5 Mathematics

## PRACTICE TEST

### SESSION 2

This session contains 20 questions.

*You may use your reference sheet during this session.  
You may **not** use a calculator during this session.*



### Directions

Read each question carefully and then answer it as well as you can. You must record all answers in this Practice Test Booklet.

For some questions, you will mark your answers by filling in the circles in your Practice Test Booklet. Make sure you darken the circles completely. Do not make any marks outside of the circles. If you need to change an answer, be sure to erase your first answer completely.

For other questions, you will need to fill in an answer grid. Directions for completing questions with answer grids are provided on the next page.

If a question asks you to show or explain your work, you must do so to receive full credit. Write your response in the space provided. Only responses written within the provided space will be scored.

**Directions for Completing Questions with Answer Grids**

1. Work the question and find an answer.
2. Enter your answer in the answer boxes at the top of the answer grid.
3. Print only one number or symbol in each box. Do not leave a blank box in the middle of an answer.
4. Under each answer box, fill in the circle that matches the number or symbol you wrote above. Make a solid mark that completely fills the circle.
5. Do not fill in a circle under an unused answer box.
6. If you need to change an answer, be sure to erase your first answer completely.
7. See below for examples of how to correctly complete an answer grid.

**Examples**

<b>0</b>	<b>.</b>	<b>4</b>	<b>3</b>	<b>2</b>	
<input type="radio"/>	<input checked="" type="radio"/>	<input type="radio"/>	<input type="radio"/>	<input type="radio"/>	<input type="radio"/>
<input checked="" type="radio"/>	0	0	0	0	0
1	1	1	1	1	1
2	2	2	2	<input checked="" type="radio"/>	2
3	3	3	<input checked="" type="radio"/>	3	3
4	4	<input checked="" type="radio"/>	4	4	4
5	5	5	5	5	5
6	6	6	6	6	6
7	7	7	7	7	7
8	8	8	8	8	8
9	9	9	9	9	9

		<b>.</b>	<b>2</b>	<b>5</b>	
<input type="radio"/>	<input type="radio"/>	<input checked="" type="radio"/>	<input type="radio"/>	<input type="radio"/>	<input type="radio"/>
0	0	0	0	0	0
1	1	1	1	1	1
2	2	2	<input checked="" type="radio"/>	2	2
3	3	3	3	3	3
4	4	4	4	4	4
5	5	5	5	<input checked="" type="radio"/>	5
6	6	6	6	6	6
7	7	7	7	7	7
8	8	8	8	8	8
9	9	9	9	9	9

			<b>4</b>	<b>3</b>	<b>8</b>
<input type="radio"/>	<input type="radio"/>	<input type="radio"/>	<input type="radio"/>	<input type="radio"/>	<input type="radio"/>
0	0	0	0	0	0
1	1	1	1	1	1
2	2	2	2	2	2
3	3	3	3	<input checked="" type="radio"/>	3
4	4	4	<input checked="" type="radio"/>	4	4
5	5	5	5	5	5
6	6	6	6	6	6
7	7	7	7	7	7
8	8	8	8	8	<input checked="" type="radio"/>
9	9	9	9	9	9

<b>6</b>	<b>8</b>	<b>1</b>	<b>9</b>		
<input type="radio"/>	<input type="radio"/>	<input type="radio"/>	<input type="radio"/>	<input type="radio"/>	<input type="radio"/>
0	0	0	0	0	0
1	1	<input checked="" type="radio"/>	1	1	1
2	2	2	2	2	2
3	3	3	3	3	3
4	4	4	4	4	4
5	5	5	5	5	5
<input checked="" type="radio"/>	6	6	6	6	6
7	7	7	7	7	7
8	<input checked="" type="radio"/>	8	8	8	8
9	9	9	<input checked="" type="radio"/>	9	9

- 21 Matthew bought  $\frac{1}{3}$  pound of cheese. He put all the cheese on 2 sandwiches. Matthew put the same amount of cheese on each sandwich.

Which of the following equations shows the amount of cheese, in pounds, on each sandwich?

Ⓐ  $\frac{1}{3} \times 6 = 2$

Ⓑ  $\frac{1}{3} \div 2 = \frac{1}{6}$

Ⓒ  $2 \times \frac{1}{3} = \frac{2}{3}$

Ⓓ  $2 \div \frac{1}{3} = 6$

22 Which of the following shows three comparison statements that are **all** true?

(A)

$2.150 = 2.15$
$1.071 < 1.09$
$5.714 < 5.8$

(B)

$2.150 = 2.15$
$1.071 > 1.09$
$5.714 < 5.8$

(C)

$2.150 > 2.15$
$1.071 > 1.09$
$5.714 > 5.8$

(D)

$2.150 < 2.15$
$1.071 < 1.09$
$5.714 > 5.8$

- 23 A baker weighed four batches of cookie dough. The weights of the batches are shown.

- 2 pounds
- 46 ounces
- 3 pounds
- 26 ounces

Which of these lists shows the weights in order from **least** to **greatest** value?

- Ⓐ 26 ounces, 2 pounds, 46 ounces, 3 pounds
- Ⓑ 26 ounces, 46 ounces, 2 pounds, 3 pounds
- Ⓒ 2 pounds, 3 pounds, 26 ounces, 46 ounces
- Ⓓ 2 pounds, 26 ounces, 3 pounds, 46 ounces

- 24 A teacher wrote this expression on a board.

$$64 \div 2 \times 4 - 3$$

The teacher asked the students to add one set of parentheses to the expression so that the value of the new expression is 5.

Which of the following expressions has a value of 5?

- Ⓐ  $64 \div (2 \times 4 - 3)$
- Ⓑ  $(64 \div 2) \times 4 - 3$
- Ⓒ  $64 \div (2 \times 4) - 3$
- Ⓓ  $64 \div 2 \times (4 - 3)$

**25** What is 18.495 rounded to the nearest **whole number**?

Enter your answer in the answer boxes at the top of the answer grid **and** completely fill the matching circles.

•	•	•	•	•	•
0	0	0	0	0	0
1	1	1	1	1	1
2	2	2	2	2	2
3	3	3	3	3	3
4	4	4	4	4	4
5	5	5	5	5	5
6	6	6	6	6	6
7	7	7	7	7	7
8	8	8	8	8	8
9	9	9	9	9	9

**26** Which of the following statements about quadrilaterals is true?

- (A) Every rhombus is also a square.
- (B) Every trapezoid is also a square.
- (C) Every rhombus is also a parallelogram.
- (D) Every trapezoid is also a parallelogram.



**This question has four parts. Be sure to label each part of your response.**

**27** The students in a class are selling bracelets and pencils to raise money for a field trip.

- They will raise \$1.50 for each bracelet they sell.
- They will raise \$0.75 for each pencil they sell.

A. Nyla sold 13 bracelets.

What is the total amount of money, in dollars, Nyla raised selling bracelets? Show or explain how you got your answer.

B. Nyla also sold 11 pencils.

What is the total amount of money, in dollars, Nyla raised selling bracelets **and** pencils? Show or explain how you got your answer.

C. The class goal is to raise a total of \$900.

- The class has 25 students.
- Each student will raise the same amount of money.

What is the total amount of money, in dollars, Nyla still needs to raise to meet her part of the class goal? Show or explain how you got your answer.

D. Tomorrow, Nyla will sell more bracelets and pencils to raise enough money to meet her part of the class goal from Part C.

How many bracelets **and** how many pencils could Nyla sell tomorrow to raise the **exact** amount of money she still needs? Give one possible answer. Show or explain how you got your answer.

**Write your answers on the next page.**



28 Compute:

$$8\frac{4}{5} - 3\frac{3}{4}$$

- Ⓐ  $5\frac{1}{1}$
- Ⓑ  $5\frac{1}{5}$
- Ⓒ  $5\frac{1}{9}$
- Ⓓ  $5\frac{1}{20}$

29 The value of the 4 in 62.43 is how many times the value of the 4 in 75.34?

- Ⓐ  $\frac{1}{10}$
- Ⓑ  $\frac{1}{100}$
- Ⓒ 10
- Ⓓ 100

- 30 A figure is made out of sugar cubes, with no gaps or overlaps, as shown.

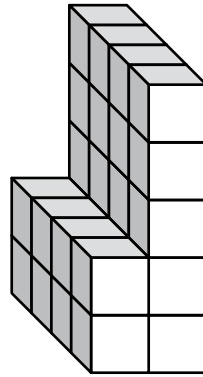

What is the total volume, in sugar cubes, of the figure?

- (A) 22 sugar cubes
  - (B) 28 sugar cubes
  - (C) 35 sugar cubes
  - (D) 40 sugar cubes
- 31 Which expression is equivalent to  $\frac{7}{8}$ ?
- (A)  $7 \times 8$
  - (B)  $7 \div 8$
  - (C)  $8 + 7$
  - (D)  $8 - 7$

**32** Which of the following expressions is equivalent to 1,000,000,000?

(A)  $10^{11}$

(B)  $10^{10}$

(C)  $10^9$

(D)  $10^8$

**33** Beatriz hiked on Saturday and Sunday.

- She hiked a distance of  $3\frac{3}{5}$  miles on Saturday.
- She hiked a distance of  $2\frac{2}{3}$  miles on Sunday.

What is the total distance Beatriz hiked on both days?

(A)  $5\frac{1}{5}$  miles

(B)  $5\frac{5}{8}$  miles

(C)  $6\frac{2}{3}$  miles

(D)  $6\frac{4}{15}$  miles

- 34 Eberto wrote this expression in his notebook.

$$10 \times 10 \times 10 \times 10$$

Which of the following is equivalent to Eberto's expression?

- (A)  $3^{10}$
- (B)  $4^{10}$
- (C)  $10^3$
- (D)  $10^4$

**This question has four parts. Be sure to label each part of your response.**

**35** The Star Ticket Company and the Best Ticket Company are both selling tickets to a game.

- A. The Star Ticket Company charges \$8 per ticket plus one \$20 handling fee per order.

Complete the table provided in your answer space to show the total costs, in dollars, of purchasing different numbers of tickets from the Star Ticket Company.

- B. The Best Ticket Company charges \$10 per ticket plus one \$7 handling fee per order.

Complete the table provided in your answer space to show the total costs, in dollars, of purchasing different numbers of tickets from the Best Ticket Company.

- C. What is the difference between the total costs, in dollars, of purchasing 5 tickets with a handling fee from the Star Ticket Company and purchasing 5 tickets with a handling fee from the Best Ticket Company? Show or explain how you got your answer.
- D. Will either the Star Ticket Company or the Best Ticket Company **always** have the least total cost, in dollars, for **any** number of tickets? Explain how you know your answer is correct.

**Write your answers on the next page.**



- 36 Which of the following attributes are **always** shared by both a rectangle and a parallelogram?

Select the **three** correct answers.

- Ⓐ four sides
  - Ⓑ four right angles
  - Ⓒ four congruent sides
  - Ⓓ two pairs of parallel sides
  - Ⓔ opposite sides that are congruent
- 37 A right rectangular prism is made of cubes, with no gaps or overlaps. Each cube has an edge length of 1 inch, as shown.

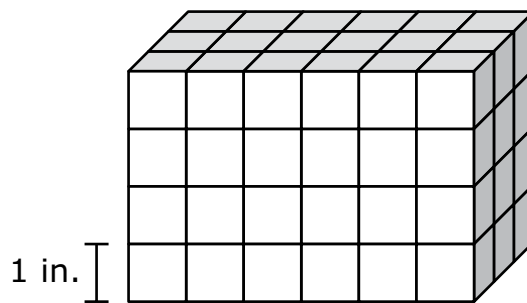

Which of the following expressions can be used to find the volume, in cubic inches, of the prism?

- Ⓐ  $6 + 4 + 3$
- Ⓑ  $6 \times 4 \times 3$
- Ⓒ  $(6 \times 4) + 3$
- Ⓓ  $6 \times (4 + 3)$

This question has two parts.

- 38 A student wrote some expressions using the numbers 3, 7, and 12.

**Part A**

The student wrote the word expression shown in this box.

7 times the difference of 12 and 3

Which of the following numerical expressions is equivalent to the student's word expression?

- (A)  $7 \times 12 - 3$
- (B)  $12 - 3 \times 7$
- (C)  $(7 \times 12) - 3$
- (D)  $(12 - 3) \times 7$

**Part B**

The student wrote this numerical expression.

$$(12 + 7) \div 3$$

Which of the following word expressions is equivalent to the student's numerical expression?

- (A)  $\frac{1}{3}$  the sum of 12 and 7
- (B) 3 divided by the sum of 12 and 7
- (C)  $\frac{1}{3}$  divided by the sum of 12 and 7
- (D) 12 added to the quotient of 7 and 3

- 39 There are 144 pages in a book. Conner will read 16 pages of the book each night. Which equation can be used to find  $t$ , the total number of nights it will take Conner to read the entire book?

- (A)  $144 \div 16 = t$   
(B)  $144 \times t = 16$   
(C)  $16 \times 144 = t$   
(D)  $t \div 16 = 144$

- 40 A rectangle has a length of  $\frac{3}{5}$  inch (in.) and a width of  $\frac{3}{8}$  inch, as shown in this diagram.

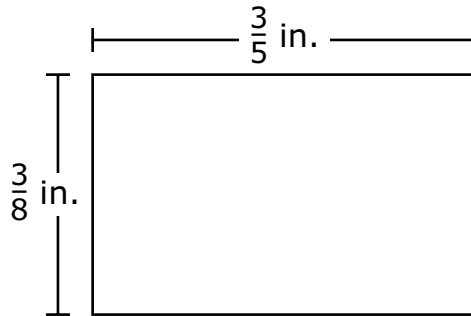

What is the area, in square inches, of the rectangle?

- (A)  $\frac{3}{40}$  square inch  
(B)  $\frac{6}{40}$  square inch  
(C)  $\frac{9}{40}$  square inch  
(D)  $\frac{39}{40}$  square inch